



LV Battery Quick Installation Guide

APbattery-51.2V/5.12kWh

Ver 1.2

Revision History

Date	Revision	Description	Owner
2025-06-09	V1.0	Initial Release	WR Wu
2025-09-19	V1.1	Content detail modifications	WR Wu
2026-02-05	V1.2	Update the certification icons	WR Wu

Contents

1. Detailed Specifications	4
2. General Information	5
2.1 Product Validity.....	5
2.2 Target Audience.....	5
2.3 Symbols.....	5
3. Safety	6
3.1 Important Safety Instructions.....	6
3.2 Installation Requirements.....	7
3.3 Grounding Requirement.....	7
3.4 Personal Safety.....	7
3.5 Equipment Security.....	7
3.6 Symbols on the Label.....	8
4. Unpacking and Storage	9
4.1 Scope of Delivery.....	9
5. Product Overview	10
5.1 Interfaces and Functions.....	10
6. Mounting	11
6.1 Installation Environment Requirements.....	11
6.2 Tools.....	12
6.3 Safety Gear.....	12
6.4 Unpacking Inspection.....	12
6.5 Wall Mounting Steps.....	13
7. System Diagram	15
7.1 Single Unit.....	15
7.2 Two (2) Batteries in Parallel Connection.....	16
7.3 Three (3) Batteries in Parallel Connection.....	17
8. Electrical Connection	18
8.1 Requirements for the Electrical Connection.....	18
8.2 Electrical Connection Steps.....	20
9. Other	23
10. Routine Maintenance	23
11. Recycling Disposal	23
12. Storage Recommendations	24
13. Shipment	24

1. Detailed Specifications

Item Name	Specification	Remark
Battery Type	Low Voltage LiFePO4 Battery	
Rated Capacity	100 Ah	
Rated Voltage	51.2 V	
Rated Current	0.6C, 60 A	
Working Voltage Range	43.2 V - 58.4 V	
Rated Energy	5.12 kWh	
Usable Energy (90%DOD)	4.61 kWh	Usable energy = Rated Energy × DoD
Max. Parallel Quantity	Max. 32 Sets In Parallel, 163.84 kWh	
Rated Charging Current	0.6C, 60 A	
Rated Discharge Current	0.6C, 60 A	
Battery Max. Charge/Discharge Power	3.07 kW/5.12 kW	
Standard Charging Method	0.5C CC to 57.6 V; CV at 57.6 V Till Current Is 0.05C	
Available SOC Range	0% to 100%	
SOC Transportation Range	50%	
Dimensions [W*D*H]	Width: 460 (±5) mm/18.11 in Depth: 165 (±5) mm/6.50 in Height: 652 (±5) mm/25.67 in	
Weight	50 kg	
Operating Temperature ¹	Charge: 0 °C to 55 °C or -5 °C to 55 °C Discharge: -15 °C to 55 °C	Charging Temperature: With heating: -5 °C to 55 °C Without heating: 0 °C to 55 °C
Storage Temperature ²	-15 °C to 55 °C	
Working Humidity	<95% RH (non-condensing)	
Altitude ³	≤2,000 m	
Communication	CAN, RS485, Dry Contact, Wi-Fi	
Designed Cycle Life (25 °C±2 °C)	6,000 Cycles	0.5C / 80%DOD / 80%SOH / 1 cycle per day
IP Rating	IP65	
Cooling	Natural Cooling	
Heating Power	230.4 W	
Fire Protection/Self Extinguishing	Yes	
Environment Protection Standard	RoHS	
UN Transportation Test Standard	UN 38.3	

1 Recommended operating temperature: 10 °C to 30 °C.

2 Recommended Storage temperature: 10 °C to 30 °C.

3 Recommended working height is less than 2,000 m, and the max. working height is 3,000 m.

2. General Information

2.1 Product Validity

This document is valid for the following models:

- APbattery-51.2V/5.12kWh

2.2 Target Audience

This document is intended for qualified persons who must perform the tasks exactly as described in this user manual.

All installation work must be performed by appropriately trained and qualified persons.

Qualified persons must possess the following skills:

- Knowledge of how batteries work and are operated.
- Training in how to deal with the dangers and risks associated with installing, repairing and using electrical devices and batteries and installations.
- Training in the installation and commissioning of electrical devices.
- Knowledge of all applicable laws, standards and directives.
- Knowledge of and compliance with this document and all safety information.

2.3 Symbols

DANGER

Indicates a hazardous situation which, if not avoided, will result in death or serious injury.

WARNING

Indicates a hazardous situation which, if not avoided, could result in death or serious injury.

CAUTION

Indicates a hazardous situation which, if not avoided, could result in minor or moderate injury.

NOTICE

Indicates a situation which, if not avoided, can result in property damage.



Information that is important for a specific topic or goal, however not related to safety.

3. Safety

3.1 Important Safety Instructions

The product has been designed and tested strictly according to the international safety requirements. As with all electrical or electronic devices, there are residual risks despite careful construction. To prevent personal injury and property damage and to ensure long-term operation of the product, read this section carefully and observe all safety information at all times.

DANGER

Danger to life due to electric shock where surge protection is not used!

If there is no surge protection, a voltage surge can be conducted into the building and to other connected devices in the same system through power cables, network cables or other types of cable. Touching live parts and cables may result in death or lethal injury due to electric shock.

- Ensure all devices in the same system and the PCS are integrated within existing surge protection systems/devices.
- Refer to local installation regulations to determine the requirements for the installation of surge protection devices.

WARNING

Danger to life due to electric shock from destruction of measurement devices due to overvoltage!

Overvoltage can damage a measurement device and result in voltage being present in the enclosure of the measurement device. Touching the live enclosure of the measuring device can result in death or lethal injuries due to electric shock.

- Only use measuring devices with a higher voltage range than the system battery voltage.

CAUTION

Risk of injury due to weight of product!

Injuries may result if the product is lifted incorrectly or dropped while being transported or mounted.

- Lift and transport the product carefully.
- Wear suitable personal protective equipment, in accordance with local regulations, when working on the product.

NOTICE

Damage to the battery system due to electrostatic discharge!

Internal components of the battery system can be irreparably damaged by electrostatic discharge.

- Ground yourself before touching any component.

3.2 Installation Requirements

Before installing, operating, and maintaining the device, the personnel must be trained to understand all safety precautions and correct operation methods.

- Only qualified and trained personnel are allowed to install, operate, and maintain devices.
- Only qualified professionals are allowed to remove safety facilities and repair equipment.
- The product must be installed and used in accordance with the specifications described in this manual (refer to "Installation" and "Technical Specifications"). Otherwise, the product may be faulty, and the resulting abnormal function or component damage is not covered by the product quality guarantee

3.3 Grounding Requirement

The following applies only to devices that need to be grounded (except energy storage units).

- When installing devices, ground them. When removing the device, remove the ground cable at the end.
- Do not damage the ground conductor.
- Do not operate the device without a ground conductor installed. Before operating the device, check the electrical connections of the device to ensure that the device is reliably grounded.

3.4 Personal Safety

- Do not operate devices or cables during thunderstorms.
- Before opening a device, wear ESD clothes, ESD gloves, and an ESD wrist strap. Remove conductive objects such as jewelry and watches to avoid electric shocks or burns.
- If there is a fire, evacuate the building or equipment area and press the fire alarm bell, or call the fire alarm number. Under no circumstances is it permitted to re-enter a burning building.
- Do not turn on the switch before the device installation is complete.

3.5 Equipment Security

- Before operation, the device should be securely fixed to the floor or other stable objects, such as walls or mounting racks.
- Do not block vents when the system is running.
- Before powering on the device, ensure that screws inside the device are secured to prevent them from falling off during running.
- After installing the device, clear the empty packing materials from the device area.
- Replace unclear hazard signs promptly.
- In any case, do not change the structure of the equipment, installation sequence, etc., without the permission of the manufacturer.
- Do not use water to clean electrical components inside or outside the cabinet under any circumstances.
- Do not drill holes directly into the cabinet.

3.6 Symbols on the Label



Beware of a danger zone

This symbol indicates that additional grounding is required if there is a need for extra grounding or equipotential bonding at the installation site.



Beware of high voltage and operating current!

The product operates at a high voltage and current. Work on the product must only be carried out by skilled and authorized personnel.



Fire Risk

The equipment contains flammable materials. Keep away from open flames or heat sources.



WEEE Designation

Do not dispose of the product together with household waste. Dispose the product in accordance with local disposal regulations for electronic waste.



The battery is recyclable

The battery can be recycled by a professional recycling organization, please refer to the relevant local regulations.



Observe the documentation

Read and understand all documentation supplied with the product.



CE marking

This product complies with CE certification requirements.

4. Unpacking and Storage

4.1 Scope of Delivery

Check the scope of delivery for completeness and any visible external damage. Contact your supplier if the package is damaged upon delivery or is incomplete or damaged.

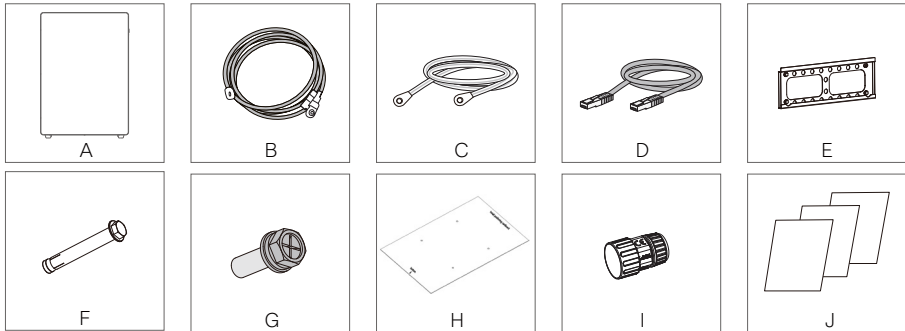

Object	Item Name	Details	Quantity	Notes
A	Battery	460x165x652 mm	1 PC	
B	Output Cable	Positive: orange plug, 25 mm ² / 4 AWG, L:1.5 m to SC25-10 ring terminal. Negative: black plug, 25 mm ² / 4 AWG, L:1.5 m to SC25-10 ring terminal.	1 SET	Continuous current capacity: 120A
C	Grounding Cable	Ground cable yellow & green / L:1 m / double OT M6	1 PC	
D	Communication cable	Standard network cable black / L:1.5 m / Double RJ45 Plug	1 PC	
E	Back Plate		1 PC	
F	Expansion Screw	M8*80mm	4 PCS	
G	Screw	M5*16 mm	2 PCS	
H	Mounting Positioning Board		1 PC	
I	RJ45 Water proof Wiring Terminal		2 PCS	
J	Manual / shipping list /shipping report		3 PCS	

5. Product Overview

5.1 Interfaces and Functions

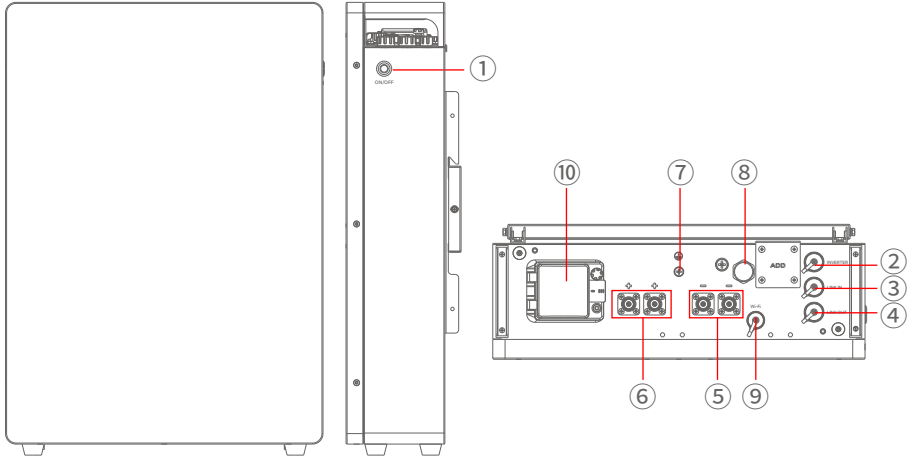

Number	Name	Details	Notes
1	Power Switch		Red LED: ALARM, Blue LED: RUN
2	INVERTER	RJ45	CAN communication to the inverter
3	LINK IN	RJ45	Internal RS485 communication between batteries
4	LINK OUT	RJ45	Internal RS485 communication between batteries
5	Port Negative x2	P-	Connected to the negative terminal of the inverter
6	Port Positive x2	P+	Connected to the positive terminal of the inverter
7	GND	M6	Yellow/Green, 10 AWG
8	Venting Valve		
9	Wi-Fi Socket		For Wi-Fi stick
10	125A DC Breaker		

• RJ45 Port Pin Definition

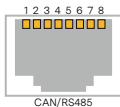
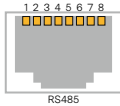
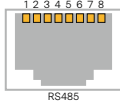
View	Item	Description	1	2	3	4	5	6	7	8
 <p>CAN/RS485</p>	2	INVERTER	-	-	-	CAN-H	CAN-L	GND	-	-
 <p>RS485</p>	3	LINK IN	-	BMS-RS485-A	BMS-RS485-B	DI+	DI-	NC	BMS-CAN-H	BMS-CAN-L
 <p>RS485</p>	4	LINK OUT	-	BMS-RS485-A	BMS-RS485-B	DO+	DO-	NC	BMS-CAN-H	BMS-CAN-L

6. Mounting

6.1 Installation Environment Requirements

1. Ensure that the equipment is installed in a dry and well-ventilated environment.
2. The installation position must be away from direct sunlight and rain.
3. The installation position must be far away from fire sources.
4. The installation position must be far away from water sources such as taps, sewer pipes, and sprinklers to prevent water seepage.
5. Do not expose the equipment to flammable or explosive gas or smoke.
6. Humidity: 5-95%RH (non-condensing); Operating temperature: -15 °C to +55 °C.

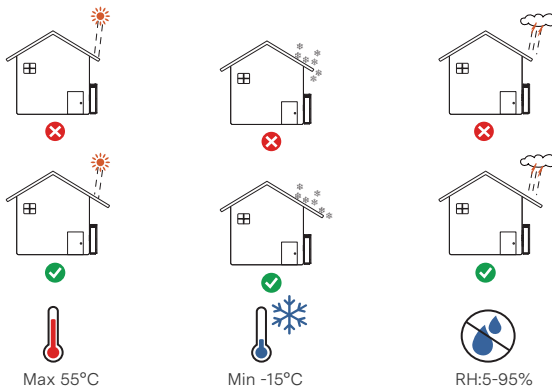

6.2 Tools

The tools in the following table could be needed during the installation.

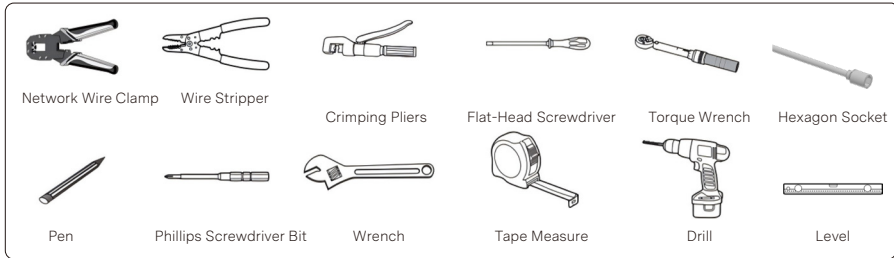

NOTE:

Use properly insulated tools to prevent accidental electric shock or short circuits.

If insulated tools are not available, cover the entire exposed metal surfaces with available insulated alternatives, except their tip, with electrical tape.

M6 x 60 expansion bolts delivered with the battery are used to install the floor support and power control module. If the length and quantity of the bolts do not meet installation requirements, prepare M6 stainless steel expansion bolts by yourself. The expansion bolts delivered with the battery are mainly used for solid concrete walls and concrete floors. If other types of walls and floors are used, ensure that the walls and floors meet the loadbearing requirements (one battery expansion module weighs 50 kg) and select the bolts by yourself.

6.3 Safety Gear

It is recommended to wear the following safety gear when dealing with the battery system.



6.4 Unpacking Inspection

When the equipment arrives at the installation site, loading and unloading should be performed according to the rules and regulations, to prevent from being exposed under sunlight. Battery should not be installed in direct sunlight. Please refer to Section 3.3.

- Before unpacking, the total number of packages shall be indicated according to the shipping list attached to each package, and the case shall be checked for good condition.
- In the process of unpacking, handle with care and protect the surface coating of the object.
- Open the package, the installation personnel should read the technical documents, verify the list, according to the configuration table and packing list, ensure objects are complete and intact, if the internal packing is damaged, should be examined and recorded in detail.

6.5 Wall Mounting Steps

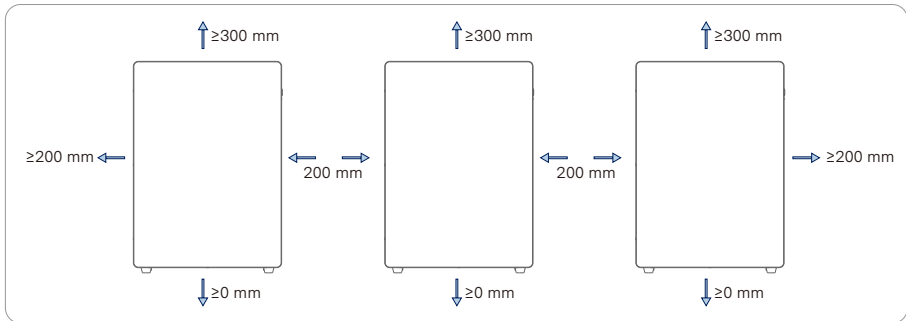

After opening the box, perform a power on test. Firstly, the blue light will flash continuously, followed by a red light that will flash once. After that, the battery will enter a normal working state, and the blue light will continue to flash.

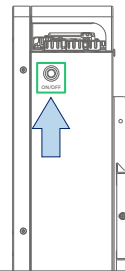

CAUTION

- The walls may contain electrical cable or pipes (for example, gas or water). Ensure that power cable or pipes are not damaged when drilling.
- Injuries may result if the product is lifted incorrectly or dropped while being transported or mounted.
- Wear suitable personal protective equipment, in accordance with local regulations, when working on the product.

NOTICE

- Expansion bolts are mainly used for solid brick-concrete walls and concrete floors. If you choose other types of walls and floors, ensure that they meet the load-bearing requirements and select the bolts yourself.
- Ensure that the mounting locating plate is level with the floor.

1

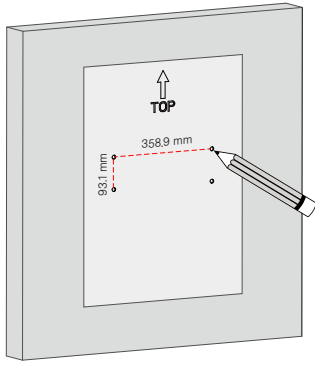

2

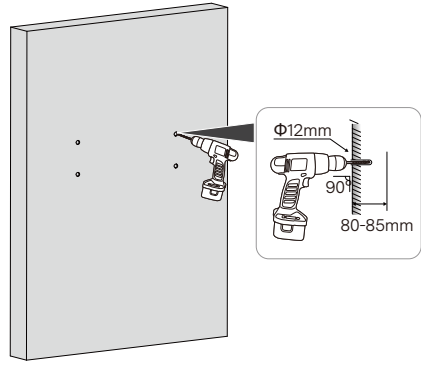

3

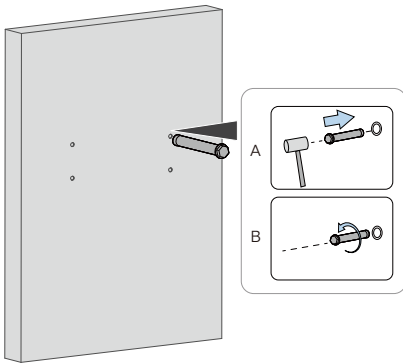

4

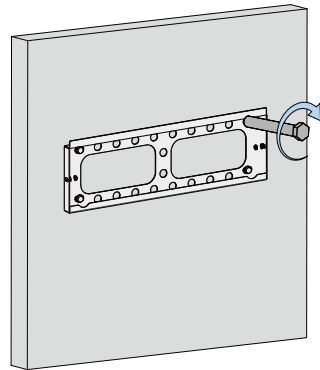

5

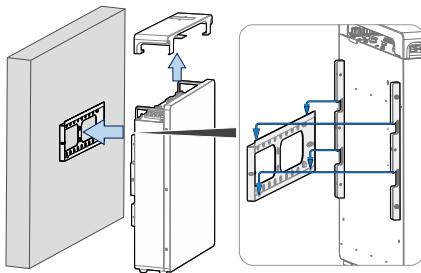

6

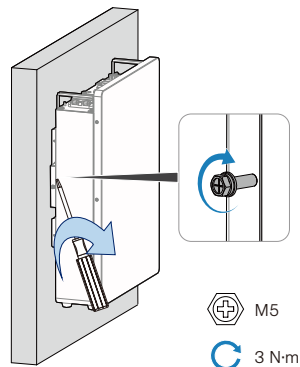

7. System Diagram

1. Before making the electrical connection, ensure that the circuit breaker / power switch of the battery and all switches connected to the energy storage system are in the OFF position. Otherwise, electric shock may occur.
2. Parallel cables require additional purchase.

7.1 Single Unit

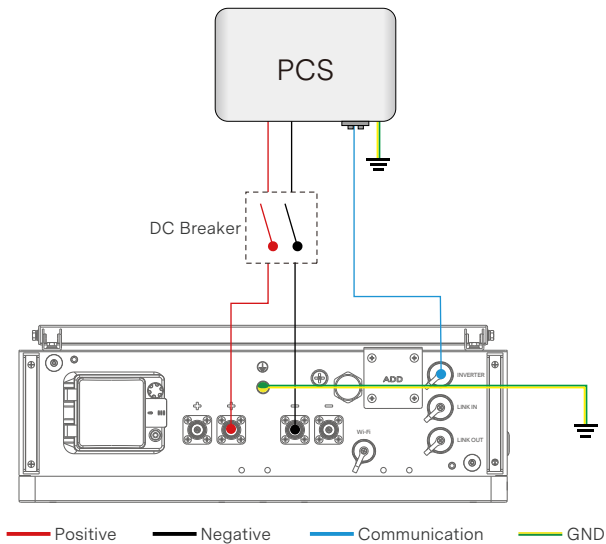

NOTICE

1. The rated output power of the cable connection is 3 kW, the maximum output power is 5kW.
2. Install circuit breakers based on local regulations.

7.2 Two (2) Batteries in Parallel Connection

With parallel cable

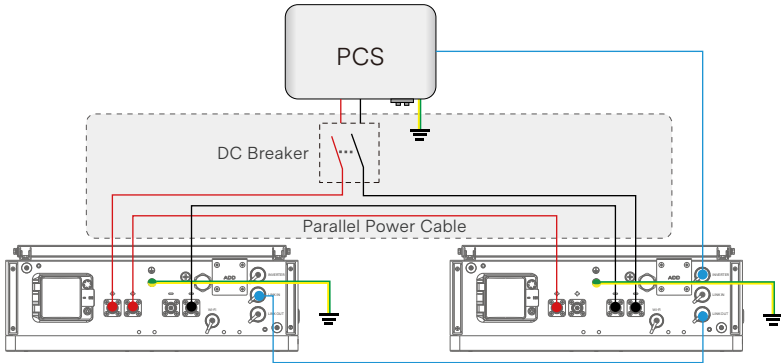

Note: The wiring diagram is suitable for the model: ELS-5K. It is not applicable for ELT-12.

WARNING

1. For parallel (cable) connection without busbar, output power is 5 kW and output current may not exceed 100A. Ensure that the PCS is limited to 100A on the battery side and install a breaker between the PCS and batteries.
2. Multiple products in parallel (cable), with equally distributed output power.
3. The parallel (cable) power cable is an optional accessory and needs to be purchased separately.

With Busbar (or DC combiner box)

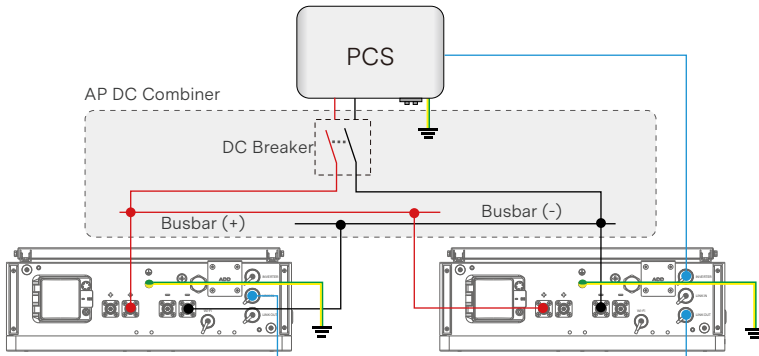

NOTICE

1. The method of cable connection with a bus-bar will output a power of $2 \times 3 \text{ kW} = 6 \text{ kW}$.
2. Install circuit breakers based on local regulations.
3. APsystems provides a DC-DC combiner that integrates both a busbar and a DC circuit breaker.

7.3 Three (3) Batteries in Parallel Connection

Left and right parallel battery

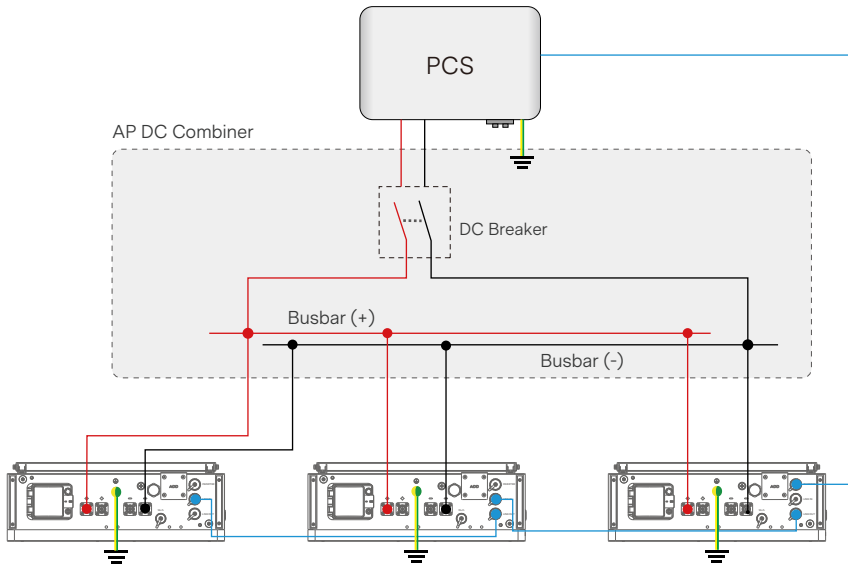

NOTICE

1. The method of cable connection with a bus-bar will output a power of $3 \times 3 \text{ kW} = 9 \text{ kW}$, and at a state-of-charge (SOC) over 70%, $3 \times 5 \text{ kW} = 15 \text{ kW}$.
2. Max. number of parallel (busbar) units: 32. Note that the max. recommended charge and discharge power is 96 kW continuous and 160kW peak.
3. Install circuit breakers based on local regulations.

8. Electrical Connection

8.1 Requirements for the Electrical Connection

8.1.1 Power Cable

Material List: (Plug components may be purchased separately from the supplier)

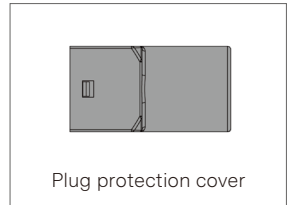
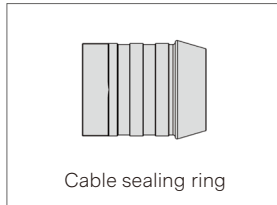
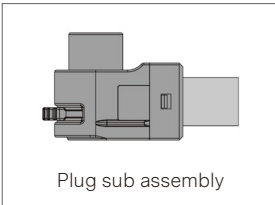

Steps:

Procedure	Schematic picture
1. Route the cable through the isolation cable sealing ring and the plug protection cover.	
2. Remove 13mm of insulation from the end of the cable.	
3. The red plug is used for the positive, and the black is for the negative power cable. The end of the cable is crimped at the terminal using a crimping clamp.	
4. Tighten the isolation cap and plug contact.	
5. Put the positive and negative plug on to the system and tighten them.	
6. Use isolation cap for unused DC plug.	

8.1.2 Communication Cable

Battery to Battery Communication Cable.

Pin definition as below, alternatively a standard straight CAT5 Ethernet cable can be used.

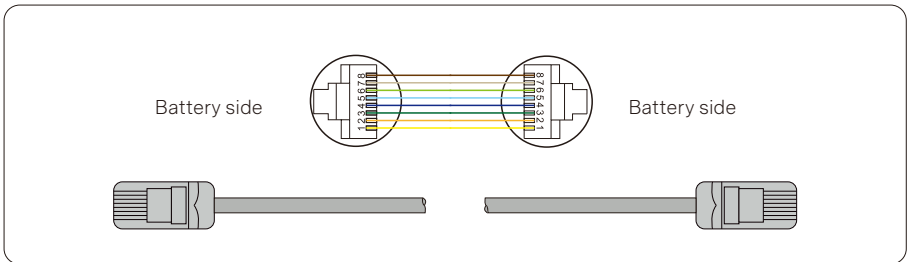

The communication between the battery and the PCS uses pins 4 and 5.

(Refer to PCS communication definition)

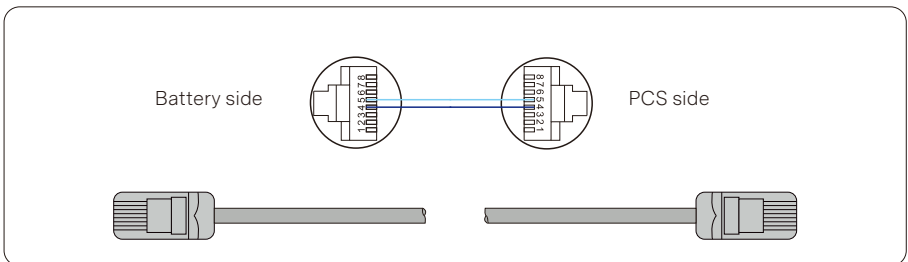

During installation, please turn off the battery power switch and check whether the power is off. The cable from the circuit breaker to the PCS is provided by the installation personnel (please refer to the Product Packaging List for cable specifications).

8.2 Electrical Connection Steps

Step 1: Ground Cable Connection

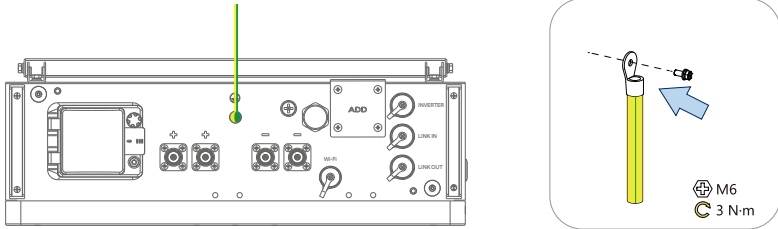

Step 2: Power Cable Connection (Single Unit)

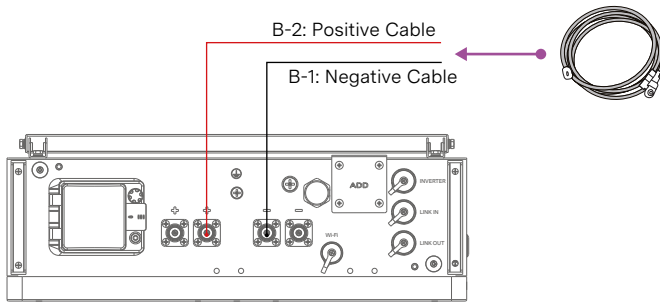

Step 2.1: Power Cable Connection (Parallel Connection with Busbar)

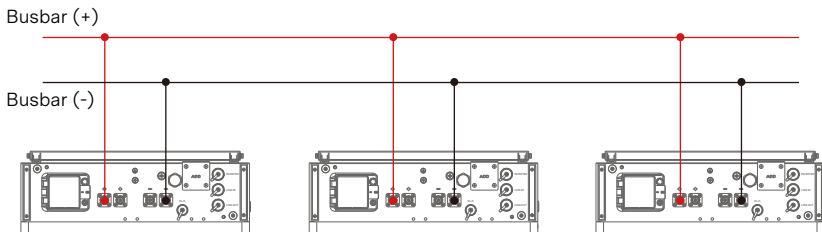

Step 3: Communication Cable Connection (Single Unit)

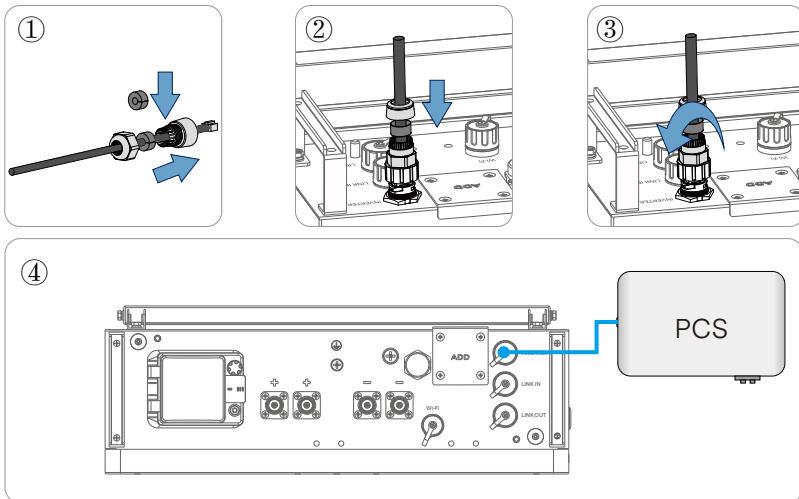

Step 4: Communication Connection (Parallel Connection)

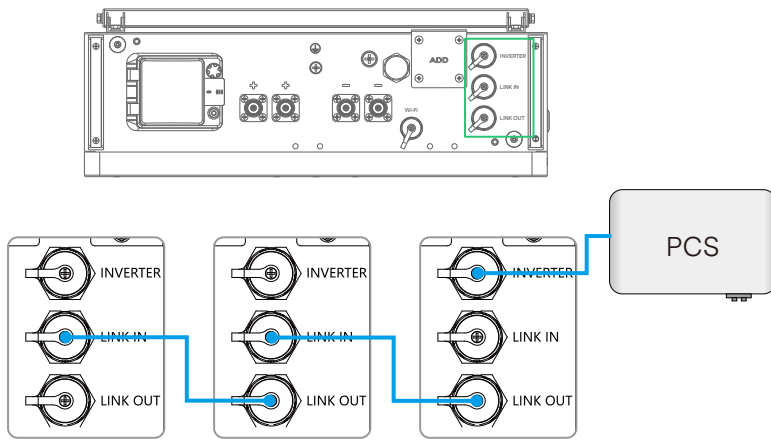

NOTICE

Make sure to turn off the batteries first, and then connect them with the parallel cable. Otherwise, the battery may fail to parallelize.

Step 5: Battery Activation

NOTICE

Failing to turn off all circuit breakers between the battery and PCS before turning on the battery power switch will disable the pre-charge/soft-start function. This would cause very high currents to flow between the PCS and battery for a short duration, potentially damaging the battery, PCS or wiring.

1. Open the cover of the circuit breaker and turn on the circuit breaker.
2. Turn on the power switch. After five seconds, a blue indicator flashes, indicating that the operation is normal.
3. Put on the cover.

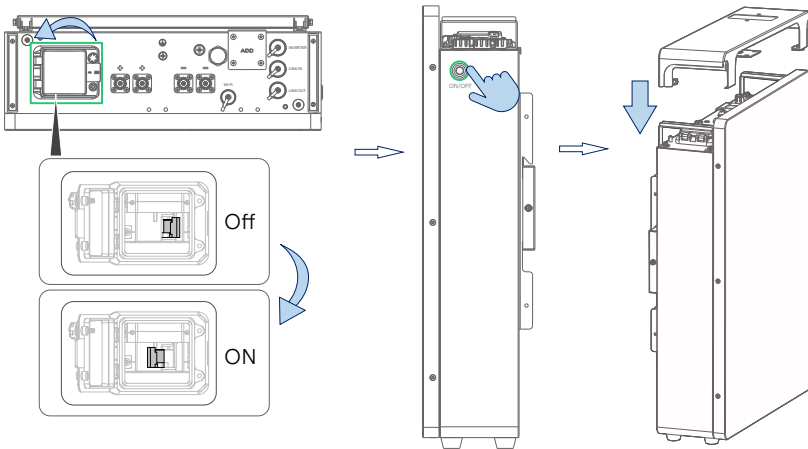

State	Standby	Charge	Discharge	Failure
Standby				
Remarks	Light 0.25 s / Lights out 3.75 s	Light 0.5 s / Lights out 0.5 s	Lights stay on	Flicker/Persist
	When the battery starts up, the red and blue lights alternately flash, indicating that the battery self-test is normal			

9. Other

Install an isolation device (such as a circuit breaker) between the PCS and the battery system to provide overcurrent protection for both the positive and negative conductors.

The steps for installing isolation devices (such as circuit breakers) are as follows:

1. Use E25–16 terminals to connect the wiring harness to the isolation device.
2. Insert the wiring harness terminals into the connection ports of the isolation device, and ensure the correct identification of the positive and negative terminals (refer to the isolation device specification sheet for details).
3. Tighten the wiring harness terminals with screws to secure them.

Note: During installation, please turn off the battery disconnect switch and verify that the power is off. The cable from the circuit breaker to the inverter is provided by the installer. (Please refer to the Product Packaging List for cable specifications.)

10. Routine Maintenance

To ensure the long-term running of the energy storage system, you are advised to maintain batteries regularly.

Check content	Inspection method	Maintenance cycle
System cleanliness	Check whether the appearance of the system is damaged or deformed.	Once every 6 to 12 months
System running state	<ol style="list-style-type: none"> 1. Check that the battery does not generate abnormal sound when it is in operation. 2. Check that the battery parameters are correctly set when the battery is running. 	Once every 6 months
Electrical connection	<ol style="list-style-type: none"> 1. Check that cables are secured. 2. Check that cables are intact, and that in particular, the parts touching the metallic surface are not scratched. 	Once every 6 months
Ground reliability	Check that ground cables are securely connected.	The first inspection is 6 months after the initial commissioning. From then on, the interval can be 6 to 12 months.

11. Recycling Disposal

The batteries may only be disposed of in accordance with the disposal regulations for used batteries applicable at the time of disposal. Immediately decommission any damaged batteries and please contact your installer or sales partner first before disposal. Ensure that the battery is not subjected to moisture or direct sunlight. Ensure quick removal by your installer.

- Batteries, including rechargeable batteries, may not be disposed of in household waste. You are legally obligated to return used batteries.
- Used batteries may contain pollutants that can damage the environment or harm your health if they are not stored or disposed of properly
- Batteries also contain important raw materials such as iron, zinc, manganese, copper, cobalt or nickel and can be recycled.

Do not dispose of batteries in household waste!



12. Storage Recommendations

- It is recommended that batteries not be stored for a long period. They should be used soon after being deployed onsite. The batteries should be handled according to the following requirements.

Required Storage Temperature	Actual Storage Temperature	Recharge Interval	Remarks
-15°C < T ≤ 55°C	T ≤ -15°C	Not allowed	Not reaching the time for recharge: Use the batteries as soon as possible.
	-15°C < T ≤ -10°C	6 months	
	-10°C < T ≤ +25°C	12 months	
	25°C < T ≤ 35°C	9 months	Reaching the time for recharge: Recharge the batteries.
	35°C < T ≤ 55°C	6 months	
	55°C < T	Not allowed	

CAUTION

The cycle life of the battery will have relative heavily reduction if not follow the above instructions to store the battery for a long term.

13. Shipment

Battery module will pre-charged to 50% SOC or according to customer requirement before shipment. The remaining capacity of battery cell is determined by the storage time and condition after shipment.

- The battery modules meet the UN38.3 certification standard.
- In particular, special rules for the carriage of goods on the road and the current dangerous goods law, specifically ADR (European Convention on the International Carriage of Dangerous Goods by Road), as amended, must be observed.

