

APsystems Microinverter User Manual

APsystems QS2 Microinverter

(For EMEA)



ALTENERGY POWER SYSTEM Inc.
emea.APsystems.com

APsystems

Karspeldreef 8, 1101 CJ, Amsterdam, The Netherlands
EMAIL: support.emea@apsystems.com

APsystems

22 Avenue Lionel Terray 69330 Jonage France
EMAIL:support.emea@apsystems.com



Please scan this QR code to have access to our APPs and Products information

Table of Contents

1.Important Safety Instructions	2
1.1 Safety Instructions	2
1.2 Radio Interference Statement	3
1.3 Symbols in lieu of words	3
2.APsystems Microinverter System Introduction	4
3.APsystems Microinverter QS2 Introduction	6
4.APsystems Microinverter System Installation	7
4.1 Additional accessories supplied by APsystems	7
4.2 Other required accessories not supplied by APsystems	7
4.3 Installation Procedures	8
4.3.1 Step 1 - Verify that grid voltage matches Microinverter rating	8
4.3.2 Step 2 – Y3 AC Bus Cable distribution	8
4.3.3 Step 3 - Attach the APsystems Microinverters to the Racking	8
4.3.4 Step 4 - Connect APsystems Microinverters to the PV Modules	9
4.3.5 Step 5 - Ground the system	10
4.3.6 Step 6 - Connect the APsystems Microinverter to AC bus cable	11
4.3.7 Step 7 - Install a Bus Cable End Cap at the end of AC bus cable	11
4.3.8 Step 8 - AC Extension Cable	12
4.3.9 Step 9 - Connect APsystems Microinverters to Grid	12
4.3.10 Step 10 - Complete the APsystems installation map	13
5.APsystems Microinverter system operating instructions	13
6.Troubleshooting	14
6.1 Status Indications and Error Reporting	14
6.1.1 Start up LED	14
6.1.2 Operation LED	14
6.1.3 GFDI Error	14
6.2 ECU_APP	14
6.3 Installer EMA (web portal or EMA Manager APP)	14
6.4 Trouble Shooting Guide	14
6.5 APsystems Technical Support	15
6.6 Maintenance	15
7.Replace a Microinverter	16
8.Technical Data	17
8.1 QS2 Microinverter Datasheet	18
9. QS2 Accessory	19
9.1 Dimensions	19
9.2 Wiring Diagram	20
10. APsystems Microinverter Installation Map	21

1. Important Safety Instructions

This manual contains important instructions to follow during installation and maintenance of the APsystems Photovoltaic Grid-connected Microinverter. To reduce the risk of electrical shock and ensure a safe installation and operation of the APsystems Microinverter, the following symbols appear throughout this document to indicate dangerous conditions and important safety instructions.

Specifications are subject to change without notice. Please ensure you are using the most recent update found at <https://emea.apsystems.com/resources/library/>

WARNING:

This indicates a situation where failure to follow instructions may cause a serious hardware failure or personnel danger if not applied appropriately. Use extreme caution when performing this task.

NOTICE:

This indicates information that is important for optimized Microinverter operation. Follow these instructions closely.

1.1 Safety Instructions

- ✓ Only qualified professionals should install and/or replace APsystems Microinverters.
- ✓ Perform all electrical installations in accordance with local electrical codes.
- ✓ Before installing or using the APsystems Microinverter, please read all instructions and cautionary markings in the technical documents and on the APsystems Microinverter system and the solar array.
- ✓ **Do NOT** disconnect the PV module from the APsystems Microinverter without first disconnecting the AC power.
- ✓ Be aware that the body of the APsystems Microinverter is the heat sink and can reach a temperature of 80°C. To reduce risk of burns, do not touch the body of the Microinverter.
- ✓ **Do NOT** attempt to repair the APsystems Microinverter. If the Microinverter is suspected to be faulty, please contact your local APsystems Technical Support to start troubleshooting and obtain a RMA (Return Merchandise Authorization) number to start the replacement process if needed. Damaging or opening the APsystems Microinverter will void the warranty.
- ✓ Caution!
When connecting a Microinverter, it is recommended to first connect the AC Bus cable to the ground then connect the AC connector to ensure proper earthing of the Microinverter, then do the DC connections. When disconnecting a Microinverter disconnect the AC by opening the branch circuit breaker first but maintain the protective earthing conductor in the branch circuit breaker connected to the Microinverter, then disconnect the DC inputs.
- ✓ Please install AC breakers on the AC side of the Microinverter.

1.2 Radio Interference Statement

EMC Compliance: The APsystems Microinverter can radiate radio frequency energy. If not installed and used in accordance with the instructions, it may cause harmful interference to radio communication.

APsystems Microinverter complies with EMC regulations, which are designed to provide reasonable protection against harmful interference in a residential installation.

Nonetheless, if the Microinverter does cause harmful interference to radio or television reception, you are encouraged to try to correct the interference by one of more of the following measures:



- A) Reorient or relocate the receiving antenna
- B) Increase the separation between the Microinverter and the receiver
- C) Connect the Microinverter into an outlet on a circuit different from that to which the receiver is connected

If none of the recommendations suggested above bring significant improvement in terms of interference, please contact your local APsystems Technical Support.

Hereby, [ALTENERGY POWER SYSTEM INC.] declares that the radio equipment type [QS2] is in compliance with Directive 2014/53/EU.

The full text of the EU declaration of conformity is available at the following internet address:
<https://emea.apsystems.com/resources/library/>

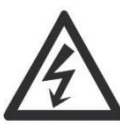
1.3 Symbols in lieu of words

 APsystems Trademark.	
	Caution, risk of electric shock.
	Caution, hot surface.
	NOTICE, danger! This device directly connected with electricity generators and public grid.
Qualified personnel	Person adequately advised or supervised by an electrically skilled person to enable him or her to perceive risks and to avoid hazards which electricity can create. For the purpose of the safety information of this manual, a "qualified person" is someone who is familiar with requirements for safety, electrical system and EMC and is authorized to energize, ground, and tag equipment, systems, and circuits in accordance with established safety procedures. The inverter and complete system may only be commissioned and operated by qualified personnel.

2.APsystems Microinverter System Introduction

The APsystems Microinverter is used in utility-interactive grid-tied applications, comprised of three key elements:

- APsystems Microinverter
- APsystems Energy Communication Unit (ECU)
- APsystems Energy Monitor and Analysis (EMA) web-based monitoring and analysis system

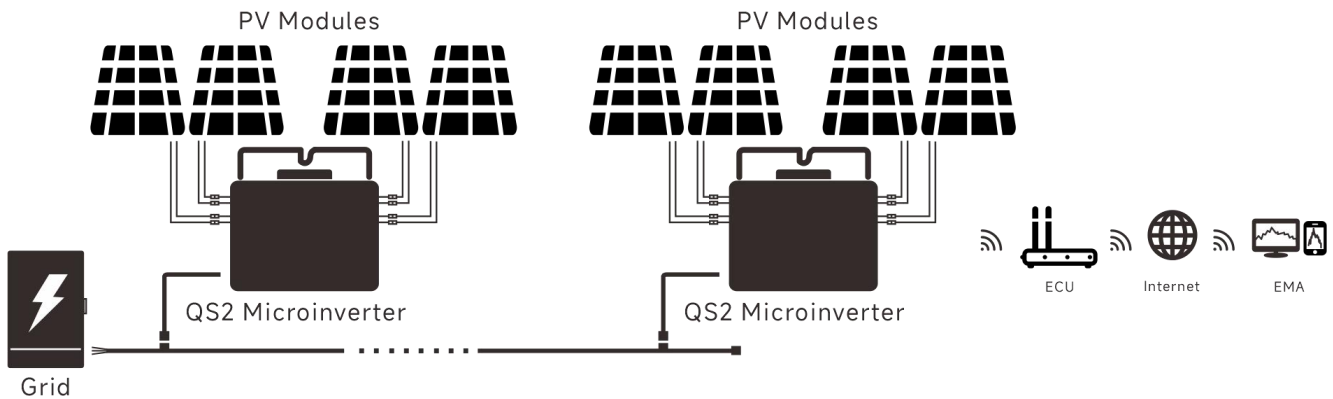

This integrated system improves safety, maximizes solar energy harvest, increases system reliability, and simplifies solar system design, installation, maintenance, and management.

Safety with APsystems Microinverters

In a typical string inverter installation, PV modules are connected in series. The voltage adds-up to reach high voltage value (from 600Vdc up to 1000Vdc) at the end of the PV string. This extreme high DC voltage brings a risk of electrical shocks or electrical arcs which could cause fire in a worst case scenario. When using an APsystems Microinverter, each 1 or 4 PV modules are connected to DC input. Voltage at the back of each PV module never exceeds PV modules V_{oc} , which is lower than 60Vdc for most of PV modules used with APsystems Microinverters, which means the DC input voltage will never exceed 120Vdc, and this low voltage will reduce the risk of electrical shock, electrical arcs and fire hazards.

APsystems Microinverters maximize PV energy production

Each input channel has individual Maximum Peak Power Tracking (MPPT) control, which ensures that the maximum power is produced to the utility grid regardless of the performance of the PV modules of other channels in the array. When PV modules in the array are affected by shade, dust, different orientation, or any situation in which one channel underperforms compared with the other channels, the APsystems Microinverter ensures top performance from the array by maximizing the performance of each channel individually within the array.

More reliable than centralized or string inverters

The distributed APsystems Microinverter system ensures that no single point of system failure exists across the PV system. APsystems Microinverters are designed to operate at full power at ambient outdoor temperatures of up to 65 deg C (or 149 F). The inverter case is designed for outdoor installation and complies with the IP67 environmental enclosure rating.

Simple to install

APsystems Microinverters are compatible with most of 60 and 72 cell PV modules or 120 and 144 half-cut cells PV modules. (In order to confirm compatibility of PV module with APsystems Microinverter, feel free to check our online “E-decider” module compatibility tool or contact your local APsystems Technical Support).

Installation requires a minimum number of accessories and Microinverters offer a lot of versatility to the installer: Microinverters can indeed be installed on different roofs with different orientation or with modules having different orientation.

In the same way, end-users can extend their system whenever they want with Microinverters.

Smart system performance monitoring and analysis

The APsystems Energy Communication Unit (ECU) is installed by simply plugging it into any wall outlet and providing an Ethernet or Wi-Fi connection to a broadband router or modem. After installing and setting the ECU (see ECU Instruction Manual), the full network of APsystems Microinverters automatically reports to the APsystems Energy Monitor and Analysis (EMA) web server.

3.APsystems Microinverter QS2 Introduction

High productivity

- Optimized for the latest high-powered PV modules
- Maximum continuous output power up to 2200VA
- 99.5% MPPT Efficiency, 96%Peak Efficiency

Proven Safety

- 60V low DC voltage,complying with rapid shutdown require ment by design
- Safety protection relay integrated
- High frequency transformers,and Galvanically isolated design
- Multiple grounding solutions

High Reliability

- Encapsulated with silicone to reduce restress on electronics,facilitate thermal dissipation, IP67 rating
- Rigorous testing including accelerated life testing
- A 24/7 energy access through apps or web-based portal facilitate remote diagnosis and maintenance

Smart Design

- Single unit connects to 4 modules
- 4 input channels with independent MPPT and monitoring function
- Encrypted wireless communication

4. APsystems Microinverter System Installation

A PV system using APsystems Microinverters is simple to install. Each Microinverter easily mounts on the PV racking, directly beneath the PV module(s). Low voltage DC wires connect from the PV module directly to the Microinverter, eliminating the risk of high DC voltage.

Installation MUST comply with local regulations and technical rules.

Special Statement: we advise installation of an RCD breaker only if required by the local electrical code.

WARNING:

1. Perform all electrical installations in accordance with local electrical codes.
2. Be aware that only qualified professionals should install and/or replace APsystems Microinverters.
3. Before installing or using an APsystems Microinverter, please read all instructions and warnings in the technical documents and on the APsystems Microinverter system itself as well as on the PV array.
4. Be aware that installation of this equipment includes the risk of electric shock.
5. Do not touch any live parts in the system, including the PV array, when the system has been connected to the electrical grid.

NOTICE:

Even if not required by local electrical code, we strongly recommend to install surge protection devices in the dedicated AC box.

4.1 Additional accessories supplied by APsystems

- AC Y3 Bus cable
- AC Y3 Bus Cable End Cap
- AC Y3 Bus Cable Y-CONN Cap
- AC Y3 Bus Cable Unlock Tool
- ECU
- AC Connectors Male/Female
- DC Extension Cable

4.2 Other required accessories not supplied by APsystems

In addition to your PV array and its associated hardware, you may need the following items:

- An AC connection junction box
- Mounting hardware suitable for module racking
- Sockets and wrenches for mounting hardware

4.3 Installation Procedures

4.3.1 Step 1 - Verify that grid voltage matches Microinverter rating

4.3.2 Step 2 – Y3 AC Bus Cable distribution

1. One end of the AC bus cable is used to access the junction box into the power grid.
2. **Wire the conductors of the AC bus: L - BROWN ; N - BLUE; PE - YELLOW GREEN.**

WARNING:

Wiring color code can be different according to the local regulation. Check all the wires of the installation before connecting to the AC bus to be sure they match. Wrong cabling can damage irreparably the Microinverters: such damage is not covered by the warranty.

During the entire cable laying and installation process, it is essential to ensure that the circuit breakers for the AC bus and the grid are turned off to prevent accidental electric shock during installation.

WARNING:

Do NOT carry the Microinverter by the AC/DC cable. This may cause the cable to partially or fully disconnect from the unit, resulting in no or poor operation.

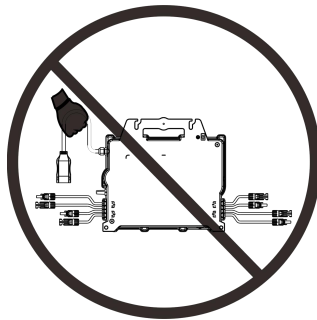

4.3.3 Step 3 - Attach the APsystems Microinverters to the Racking

1. Mark the location of the Microinverter on the rack, with respect to the PV module junction box or any other obstructions.
2. Mount one Microinverter at each of these locations using hardware recommended by your module racking vendor.

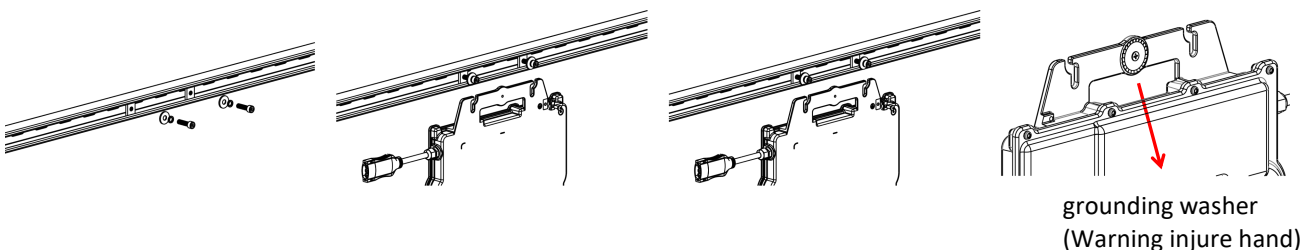

WARNING:

Install the Microinverters (including DC and AC connectors) under the PV modules to avoid direct exposure to rain, UV or other harmful weather events. Allow a minimum of 1.5 cm (3/4") below and above the casing of the Microinverter to allow proper air flow. The racking must be properly grounded as per local electrical code.

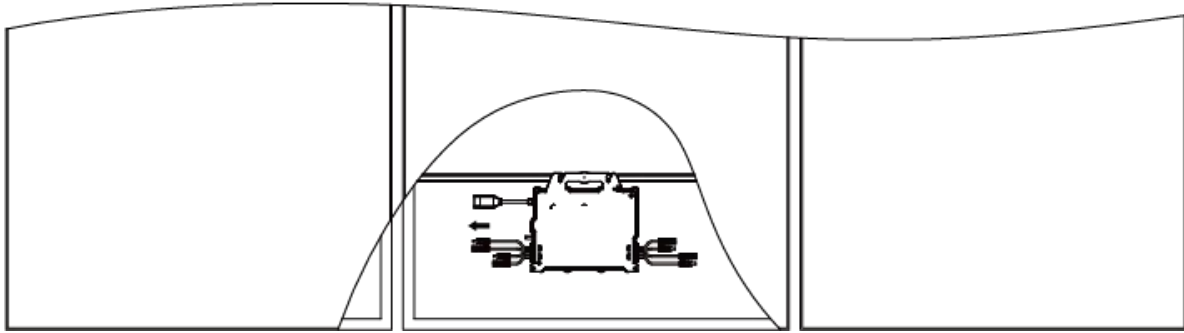

Thoroughfare

TIP:

When flush-mounting photovoltaic modules on the rooftop, please reserve the DC connectors, antenna, and LED indicator of the Microinverter facing outwards to facilitate monitoring of indicator status and ensure optimal communication quality.

4.3.4 Step 4 - Connect APsystems Microinverters to the PV Modules

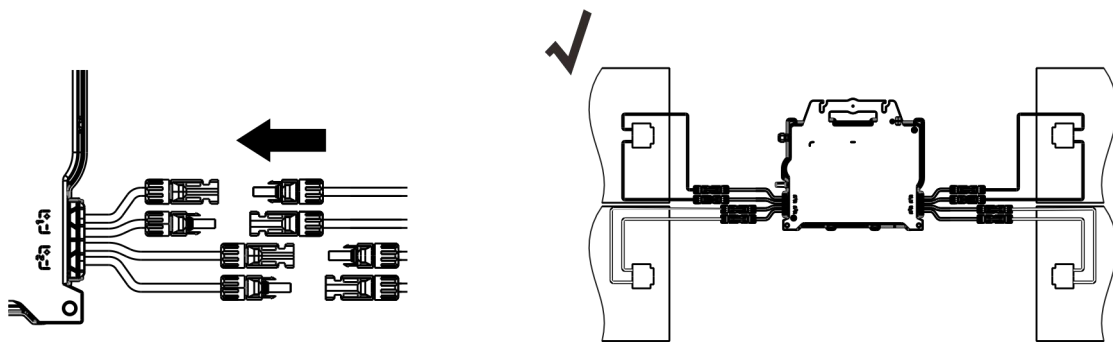

NOTICE:

Each channel connects 1 PV modules in series (For PV modules with $V_{oc} < 60V$).

NOTICE:

When plugging in the DC cables, the Microinverter should immediately blink green ten times. This will happen as soon as the DC cables are plugged in and will show that the Microinverter is functioning correctly. This entire check function will start and end within 10 seconds of plugging in the unit, so pay careful attention to these lights when connecting the DC cables.

WARNING:

Double check to make sure all of the AC and DC wiring has been correctly installed. Ensure that none of the AC and/or DC wires are pinched or damaged. Make sure that all of the junction boxes are properly closed.

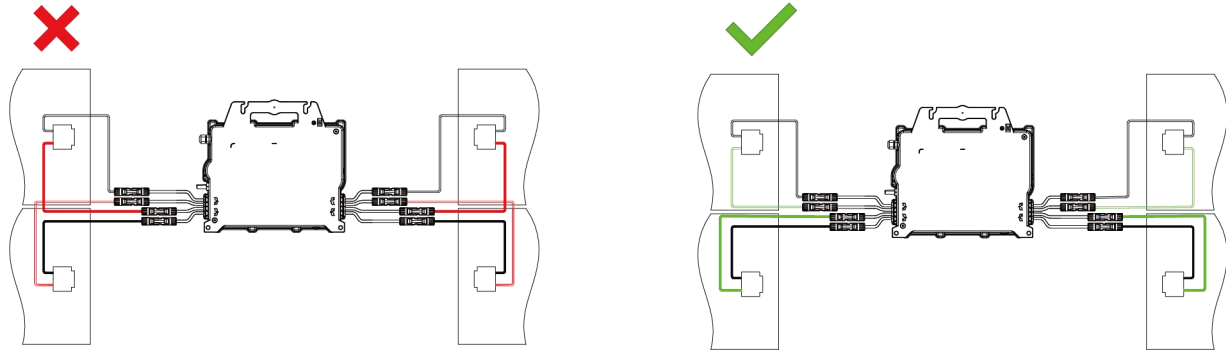

WARNING:

1. Each PV panel must be carefully connected to the same channel.
2. Make sure to not split positive and negative DC cables into two different input channels:
Microinverter will be damaged and warranty will not apply.
3. Please ensure each DC cable's length within 3 meters.

4.3.5 Step 5 - Ground the system

There are three ways to connect grounds on the APsystems QS2:

- ① Y3 AC Bus cable has an embedded PE wire to ground the inverters in the AC circuit box
- ② If the rack is grounded, the grounding washer on the inverter could create a tight bond onto the rack as a ground connection. This is also a solution to ground the rack through inverter when the inverters are grounded.
- ③ If an external connection is necessary, an external wire can be bonded to the grounding lug on the exterior of the inverter and connected to ground.

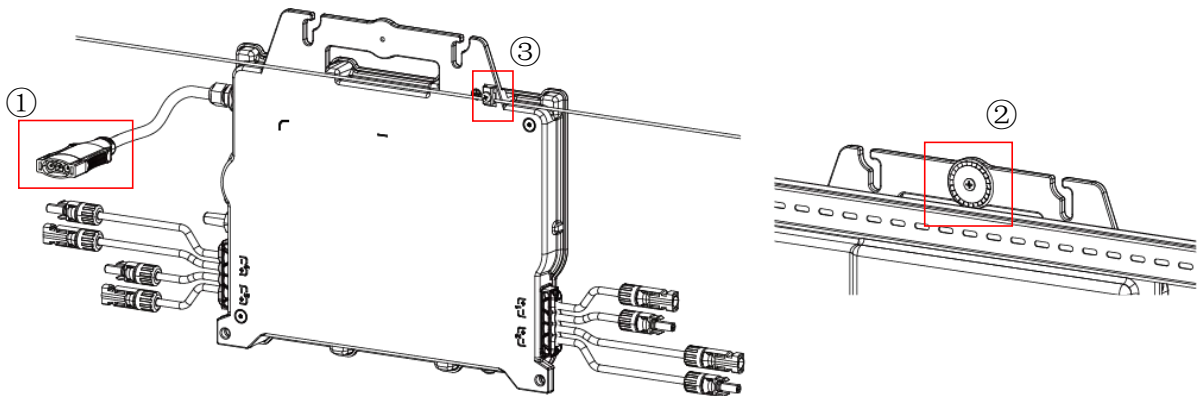

4.3.6 Step 6 - Connect the APsystems Microinverter to AC bus cable

Insert the Microinverter AC connector into the bus cable connector. Make sure to hear the “click” as a proof of robust connection.

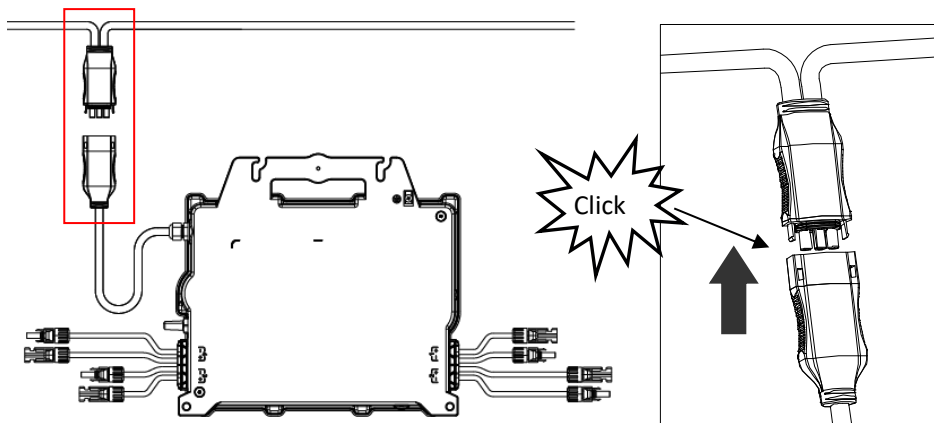

Best Practice: Use the Bus Cable Unlock Tool of AC Bus to disconnect the connectors.

AC connector interface as from left to right.

Cover any unused connectors with Bus Cable Y-CONN to protect the unused connectors.

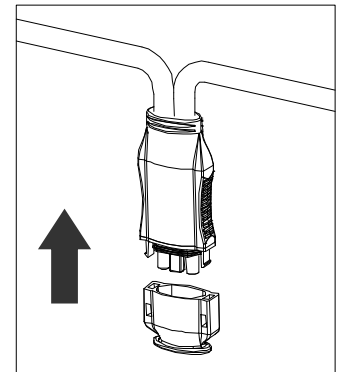
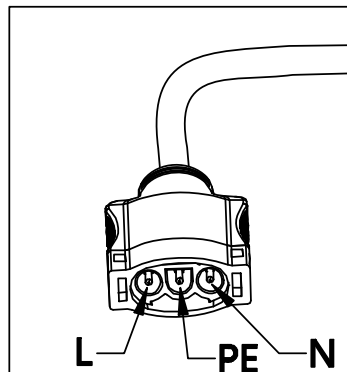
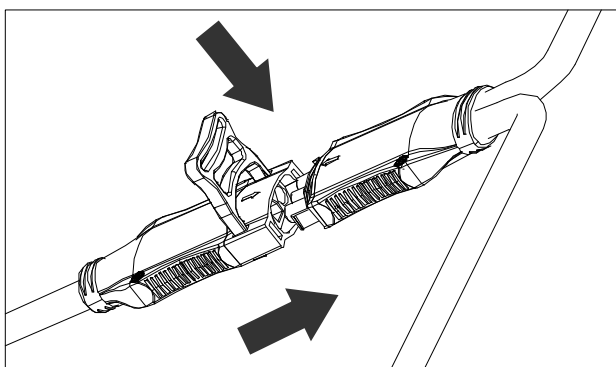

4.3.7 Step 7 - Install a Bus Cable End Cap at the end of AC bus cable

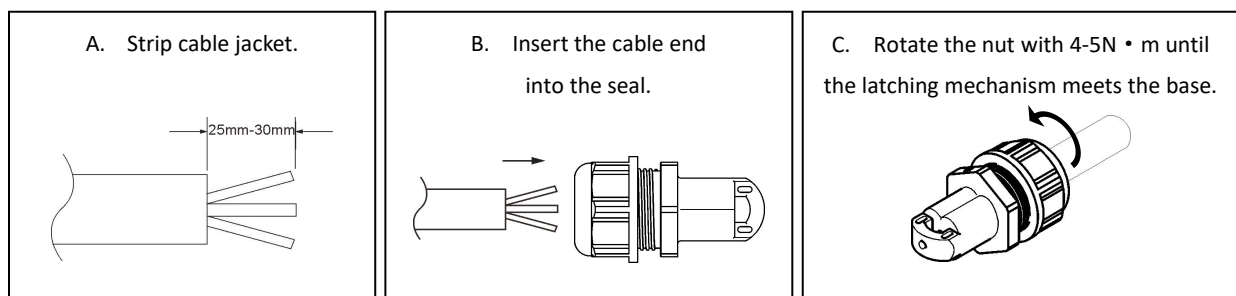

4.3.8 Step 8 - AC Extension Cable

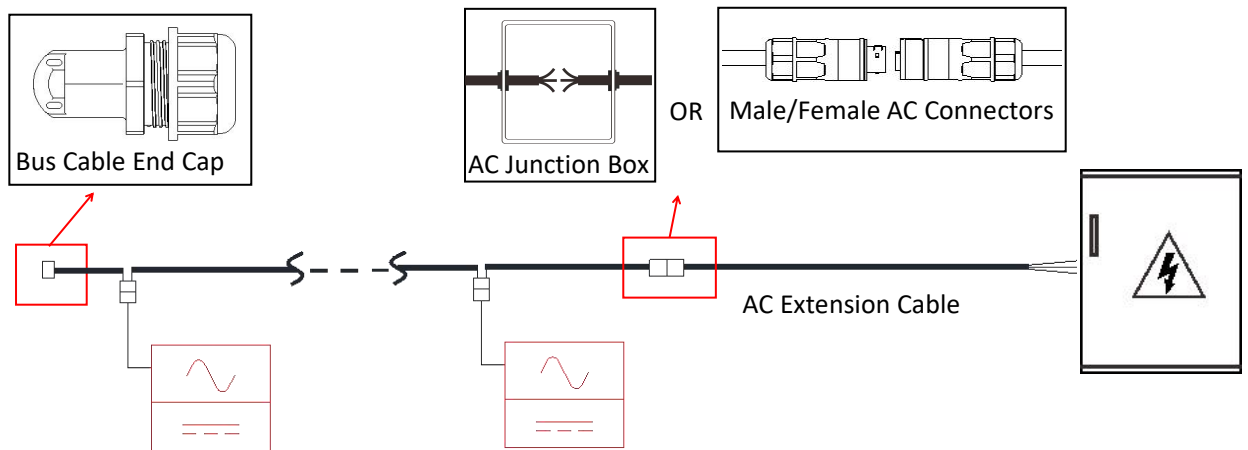

When AC extension cable is needed, users could connect the AC bus cable and AC extension cable in a junction box or use a pair of male/female AC connectors that APsystems provides as optional accessory.

4.3.9 Step 9 - Connect APsystems Microinverters to Grid

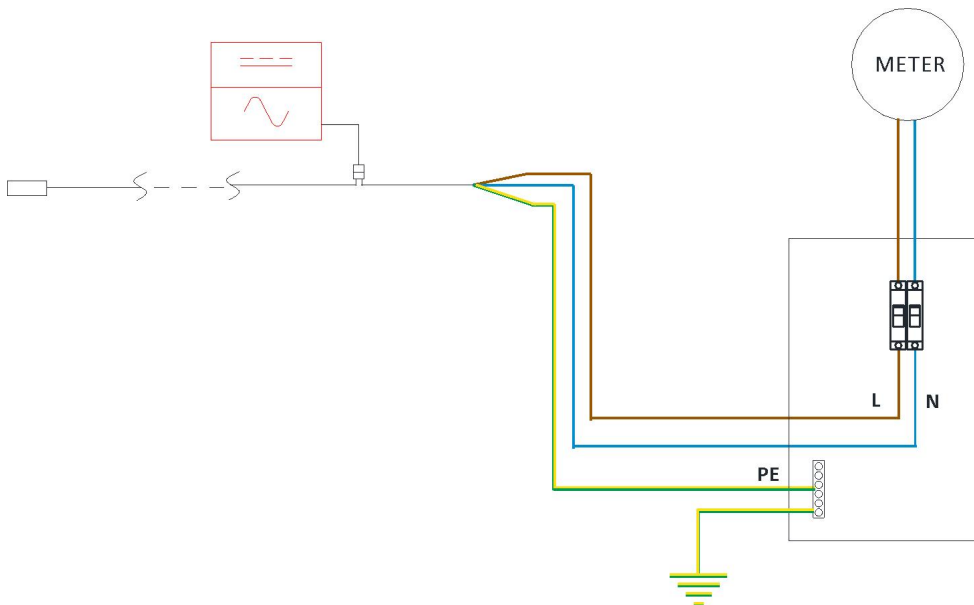

NOTICE:

1. Please install bi-polar circuit breakers with proper rated current or according to the local regulation, which are mandatory to connect to grid.
2. Leakage current breakers or AFCI/GFCI breakers are not recommended to install.

4.3.10 Step 10 - Complete the APsystems installation map

1. Each APsystems Microinverter has 2 removable serial number labels.
2. Complete installation map by sticking ID label of each Microinverter at the right location.
3. The second serial number label, could be stuck on the solar module frame, which could help later to confirm the position of the Microinverter without dismantling the PV module.

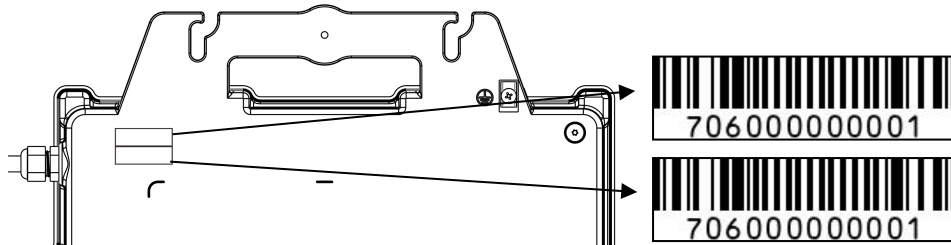

NOTICE:

1. The layout of the Microinverters' serial numbers installation map is only suitable for typical installation
2. Installation Map is available in the last page appendix of this manual.
3. Use ECU_APP (available in the EMA Manager) to scan the serial numbers on the map when setting up the ECU (see ECU instruction manual for more info).

5.APsystems Microinverter system operating instructions

To operate the APsystems Microinverter PV system:

1. Turn ON the AC circuit breaker on each Microinverter AC branch circuit.
2. Turn ON the main utility-grid AC circuit breaker. Your system will start producing power after approximately one minute of waiting time.
3. Microinverter data will be available in the EMA Manager APP or in the EMA web portal.

Alternatively, LED sequences could be an indicator of Microinverters status (see section 6.1)

NOTICE:

Once the ECU has been commissioned properly, the APsystems Microinverters will start to send performance data to the ECU. The time required for all of the Microinverters in the system to report to the ECU will vary depending on the number of Microinverters in the system.

6.Troubleshooting

Qualified personnel can use the following troubleshooting steps if the PV system does not operate correctly:

6.1 Status Indications and Error Reporting

Assuming they are easily accessible and visible, Operation LEDs can give a good indication of the Microinverters status.

6.1.1 Start up LED

Ten short green blinks when DC power is first applied to the Microinverter indicates a successful Microinverter startup.

6.1.2 Operation LED

Flashing Slow Green (5 sec. gap) - Producing power and communicating with ECU

Flashing Slow Red (5 sec. gap) - Not producing power

Flashing Fast Green (2 sec. gap) - Not communicating with ECU over 60mins, but still producing power.

Flashing Fast Red (2 sec. gap) - Not communicating with ECU over 60mins and not producing power.

Steady Red – default, DC side ground fault protection, see 6.1.3

6.1.3 GFDI Error

A solid red LED indicates the Microinverter has detected a Ground Fault Detector Interrupter (GFDI) error in the PV system. Unless the GFDI error has been cleared, the LED will remain red and the ECU will keep reporting the fault. Please contact your local APsystems Technical Support.

6.2 ECU_APP

APsystems ECU_APP (available in the EMA Manager APP) is the recommended tool to do on-site troubleshooting. When connecting the ECU_APP to the ECU hot spot (please check ECU User Manual for more detailed information), installer can check every Microinverter status (production, communication) but also ZigBee signal strength, grid profile and other insightful data helping the troubleshooting.

6.3 Installer EMA (web portal or EMA Manager APP)

Before going on site for troubleshooting, installer can also check all information remotely using his installer account, either on the web or using the EMA Manager APP (see EMA Manager APP User Manual for more detailed information). Having access to module data (DC, AC, voltages and currents) gives the first indication on potential issues.

6.4 Trouble Shooting Guide

Professional installers can also refer to our Troubleshooting Guide (<https://emea.apsystems.com/resources/library/>, section libraries) to have more in depth guideline on how to troubleshoot and fix PV installations powered by APsystems Microinverters.

6.5 APsystems Technical Support

APsystems local Technical Support team is available to support professional installers to get familiar with our products and to troubleshoot installations when needed.

WARNING:

Do not attempt to repair APsystems Microinverters. Please contact your local APsystems Technical Support.

NOTICE:

1. Never disconnect the DC wire connectors under load. Ensure that no current is flowing in the DC wires prior to disconnecting.
2. Always disconnect AC power before disconnecting the PV module wires from the APsystems Microinverter.
3. The APsystems Microinverter is powered by PV module DC power. AFTER disconnecting the DC power, when reconnecting the PV modules to the Microinverter, be sure to watch for the quick red light followed by ten short green LED flashes.

6.6 Maintenance

APsystems Microinverters do not require any specific regular maintenance.

7. Replace a Microinverter

Follow the procedure to replace a failed APsystems Microinverter

- A. Disconnect the APsystems Microinverter from the PV Module, in the order shown below:
 - 1. Disconnect the AC by turning off the branch circuit breaker.
 - 2. Disconnect the inverter AC connector from the AC Bus.
 - 3. Disconnect the PV module DC wire connectors from the Microinverter.
 - 4. Remove the Microinverter from the PV array racking.

- B. Install a replacement Microinverter to the rack. Remember to observe the flashing green LED light as soon as the new Microinverter is plugged into the DC cables.

- C. Connect the AC cable of the replacement Microinverter to the AC bus.

- D. Close the branch circuit breaker and verify proper operation of the replacement Microinverter.

- E. Update the Microinverter in EMA Manager through "Replace" function and update the system's map with new serial number labels.

8. Technical Data

WARNING:

1. Be sure to verify that the voltage and current specifications of your PV module are compatible with the range allowed on APsystems Microinverter. Please check the Microinverter datasheet.
2. DC operating voltage range of the PV module must be within allowable input voltage range of the APsystems Microinverter.
3. The maximum open circuit voltage of the PV module must not exceed the specified maximum input voltage of the APsystems.

8.1 QS2 Microinverter Datasheet

Model	QS2
Region	EMEA
Input Data (DC)	
MPPT Voltage Range	28V-48V
Operating Voltage Range	26V-60V
Maximum Input Voltage	60V
Maximum Input Current	20A x 4
Isc PV	25A x 4
Output Data (AC)	
Maximum Continuous Output Power	2200VA
Nominal Output Voltage/Range ⁽¹⁾	230V/184V-264V
Nominal Output Current	9.6A
Nominal Output Frequency/ Range ⁽¹⁾	50Hz/48Hz-52Hz
Power Factor(Default/Adjustable)	0.99/0.9 leading...0.9 lagging
Maximum Units per 2.5mm ² AC Bus Cable ⁽²⁾	2
Maximum Units per 4mm ² AC Bus Cable ⁽²⁾	3
Zigbee Frequency Range	2405MHz - 2480MHz
Zigbee Maximum Power (EIRP)	9.97 dBm
Mechanical Data	
Operating Ambient Temperature Range ⁽³⁾	- 40 °C to + 65 °C
Storage Temperature Range	- 40 °C to + 85 °C
Dimensions (W x H x D)	365mm×272mm×40.6mm
Weight	6.6kg
DC Connector Type	Stäubli MC4 PV-KBT4&KST4
Cooling	Natural Convection - No Fans
Enclosure Environmental Rating	IP67
Pollution Degree Classification	PD3
Operate Relative Humidity Range	4%~100%
Maximum Altitude	<2000m
Overvoltage Category	OVC II For PV Input Circuit, OVC III For Mains Circuit
Warranty ⁽⁵⁾	12 Years Standard ; 25 Years Optional
Efficiency	
Peak Efficiency	96.00%
Nominal MPPT Efficiency	99.50%
Night Power Consumption	20mW
Features	
Communication (Inverter To ECU) ⁽⁴⁾	Encrypted ZigBee
Isolation Design	High Frequency Transformers, Galvanically Isolated
Energy Management	EMA web portal, EMA Manager, EMA APP

(1) Nominal voltage/frequency range can be extended beyond nominal if required by the utility.

(2) Limits may vary. Refer to local requirements to define the number of microinverters per branch in your area.

(3) The inverter may enter to power de-grade mode under poor ventilation and heat dissipation installation environment.

(4) Recommend no more than 80 inverters register to one ECU for stable communication.

(5) To be eligible for the warranty, APsystems microinverters need to be monitored via the EMA portal. Please refer to our warranty

T&Cs available on emea.APsystems.com.

© All Rights Reserved

Specifications subject to change without notice please ensure you are using the most recent update found at web : emea.APsystems.com

9. QS2 Accessory

9.1 Dimensions

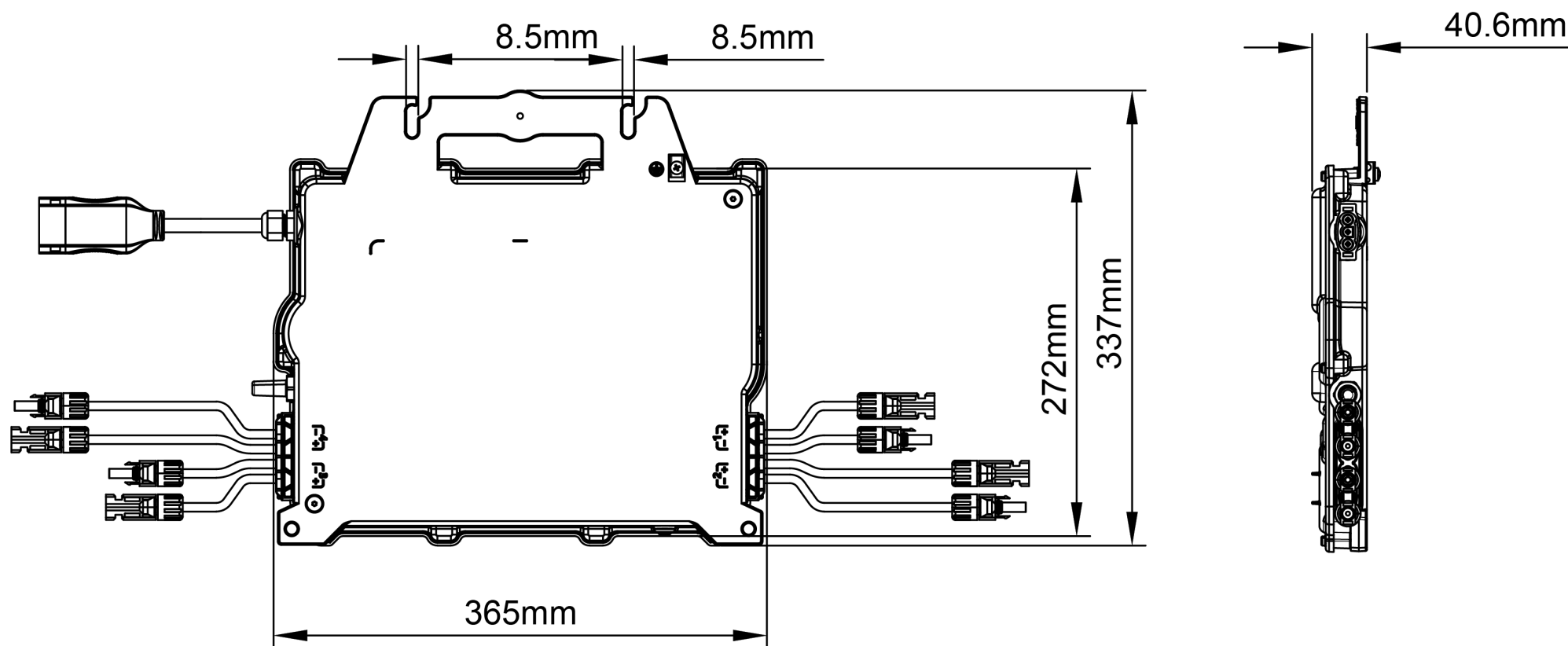

9.2 Wiring Diagram

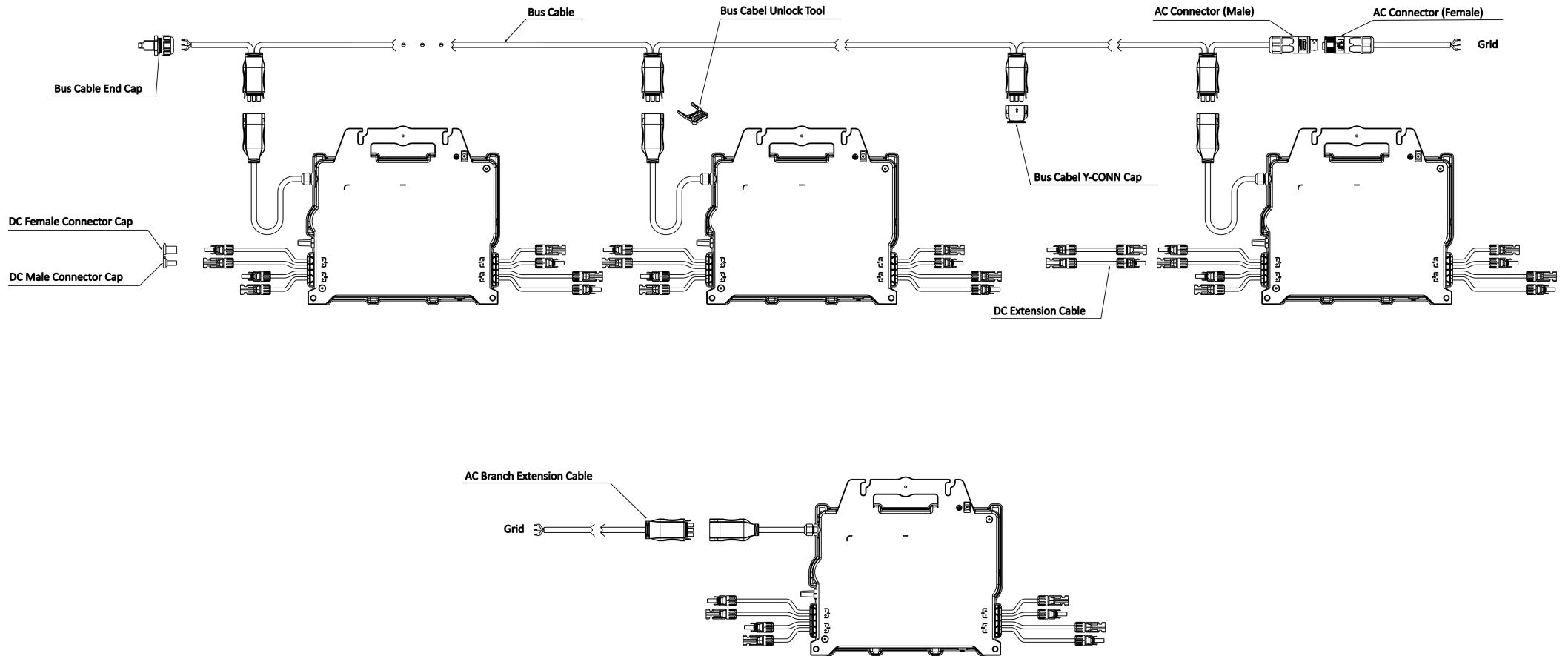

10. APsystems Microinverter Installation Map

The APsystems Installation Map is a diagram of the physical location of each microinverter in your PV installation. Each APsystems microinverter has two serial number labels. Peel the one label and affix it to the respective location on the APsystems installation map.

Installation Map Template

Installer:		PV module type:		Qty:		Sheet ___ of ___	 N
Owner:		Microinverter type:		Qty:			
	Column 1	Column 2	Column 3	Column 4	Column 5	Column 6	Column 7
Row 1							
Row 2							
Row 3							
Row 4							
Row 5							
Row 6							
Row 7							
Row 8							
Row 9							
Row 10							